

PROGETTO

APHRODITE

PERFUME IS THE KEY TO OUR MEMORY



LABORATORIO DI GRAFICA

PACKAGING AND ADVERTISING EXPERIENCE

Classe 5^aC Grafica a.s. 2019_2020



Il progetto APHRODITE è una esercitazione didattica volta ad approfondire le conoscenze ed esperienze del mondo della comunicazione.

Il PROFUMO è il tema di questo lavoro.

Profumo per la donna e anche per l'uomo. Un tema molto stimolante che ci trascina in nuove emozioni. Quelle stesse emozioni, da vivere a occhi chiusi, che trasmettono le fragranze e anche il semplice rapporto tattile con il contenitore e con la pressione del dito sull'erogatore.



MANUALE OPERATIVO
FIRMA/MARCHIO STILISTA

Lorraine

Lorraine

IL SUO SIGNIFICATO

Il marchio è stato scelto dall'idea di essere delicato e di esprimere finezza. Il nome proviene dal nome Lorena, che è il femminile di Loris o Lorenzo in francese. Nome da donna perché risulta più adatto al contesto e in francese perché la Francia è il luogo perfetto dove le forti emozioni hanno la possibilità di spiccare, il font utilizzato è Mr De Haviland Regular. Il marchio rappresenta la firma dello stilista usata su ogni prodotto.

Lorraine

Lorraine

Lorraine

Lorraine

Lorraine

Lorraine

Lorraine

100%

Lorraine

50%

Lorraine

25%

PROVE DI LEGGIBILITÀ DEL LOGO IN NEGATIVO

Lorraine

100%

Lorraine

50%

Lorraine

25%



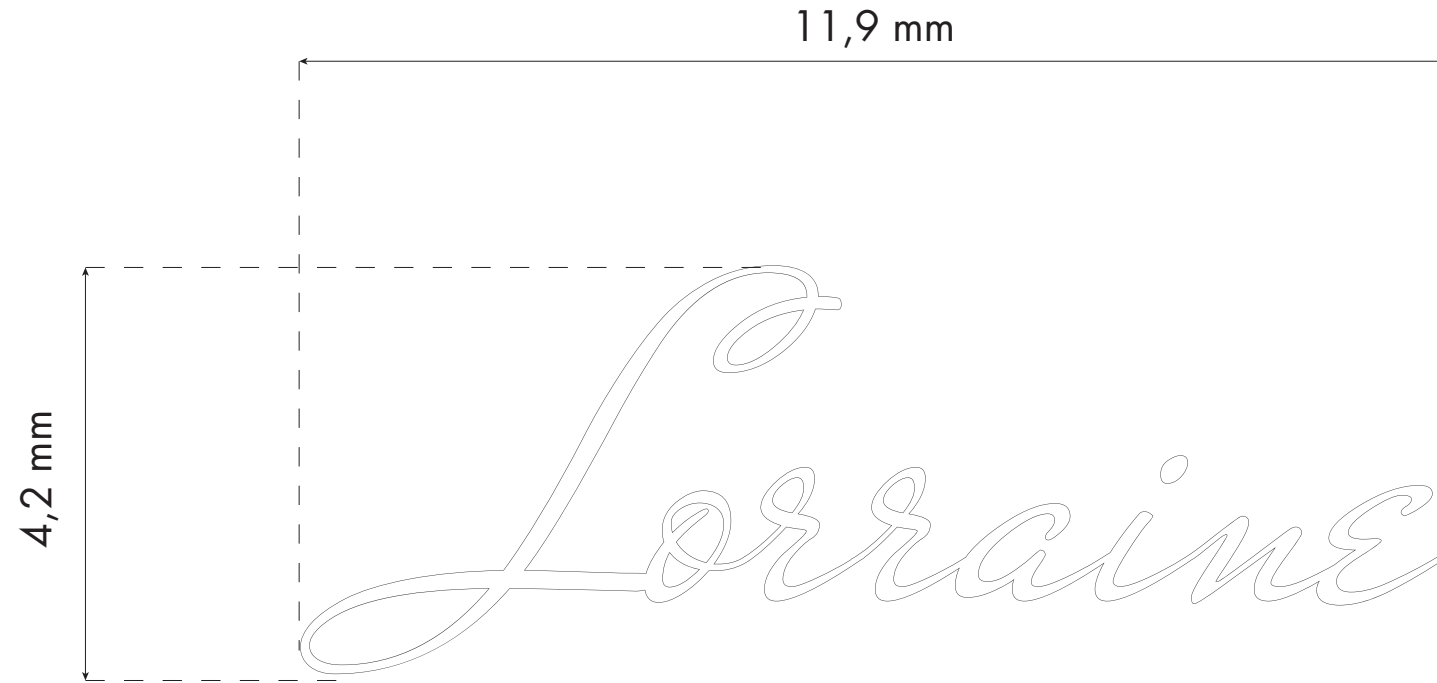



The word "Lorraine" is written in a cursive script. A red diagonal line is drawn across the text, causing the letters to be stretched and distorted.

Non deformare o distorcere il logo



The word "Lorraine" is written in a cursive script. A red diagonal line is drawn across the text. The text has a soft, grey shadow effect applied behind it.

Non applicare effetti al logo



The word "Lorraine" is written in a cursive script. A red diagonal line is drawn across the text. A solid black dot is placed above the letter 'i'.

Non cambiare gli elementi del logo



The word "Lorraine" is written in a cursive script. A red diagonal line is drawn across the text. This is the original, unaltered logo.

Logo originale





LORRAINE PRESENTA

Stulia 

Hulia

Il logo realizzato per il nome del profumo prende come figura il simbolo della potenza femminile, la potenza di una regina. Il nome "Hulia" è una parola turca che significa una giornata da sogno che porta felicità.

Nella sua eleganza riesce a far sentire a proprio agio e sicura di sé qualsiasi donna che decide di indossare questo profumo.

Gli elementi grafici del logo entrano in perfetta armonia con il font scelto, per via della sua eleganza.

L'elemento caratterizzante è la corona in pendenza sulla lettera finale del logo.

Hulia

Hulia

Hulia

Hulia[♠]

Fulvia

Fulvia

Fulvia 

100%

Fulvia 

50%

Fulvia 

25%

Fulvia 

100%

Fulvia 

50%

Fulvia 

25%





DIMENSIONI DELLA BOCCETTA

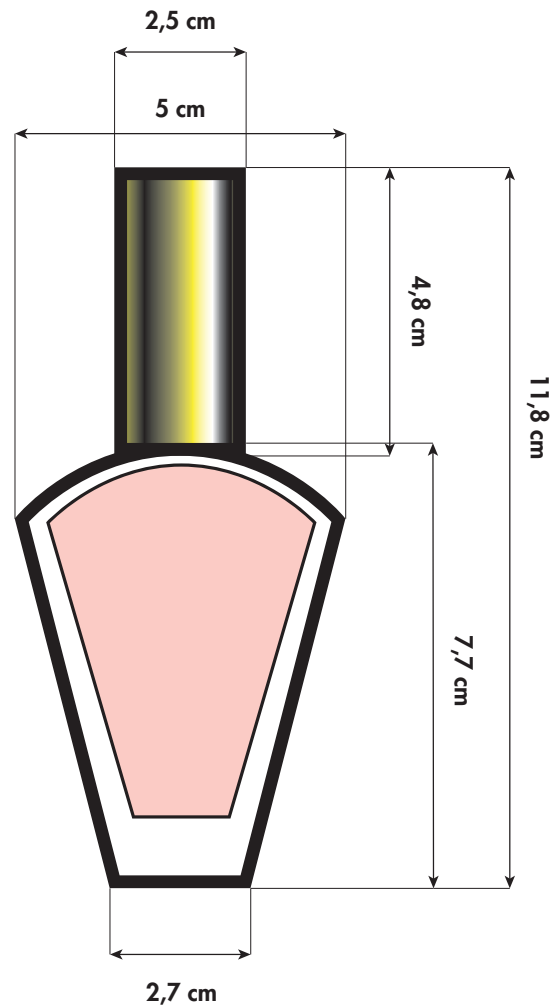



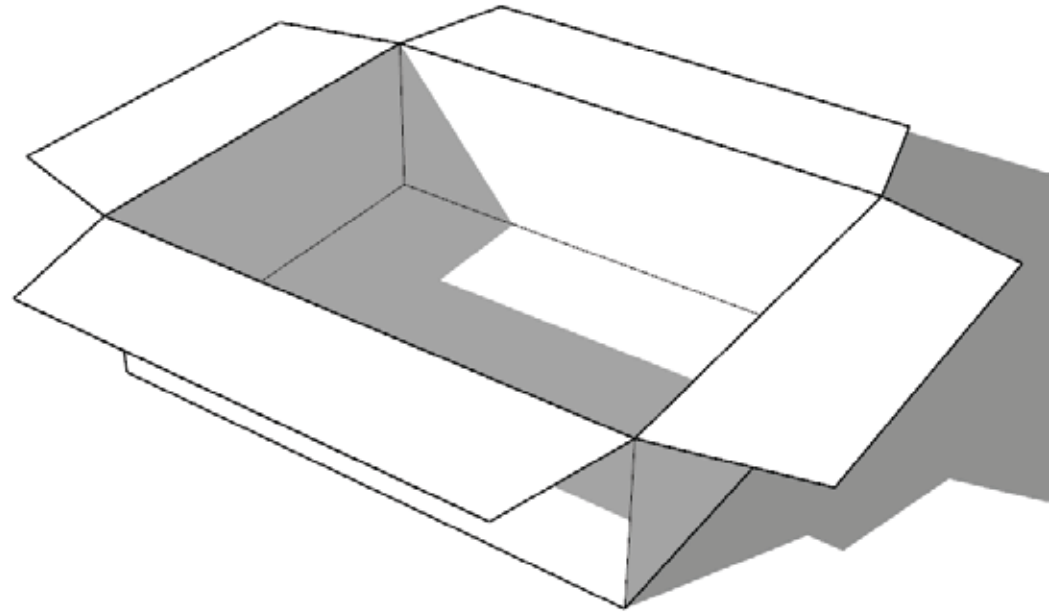
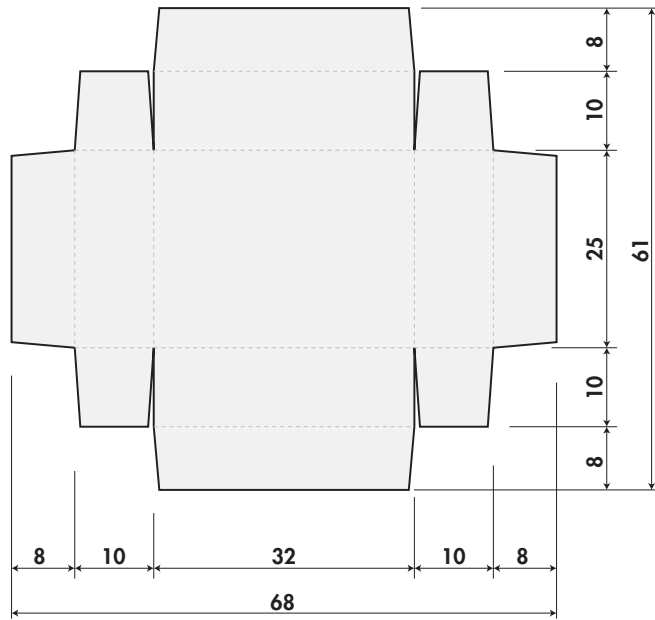

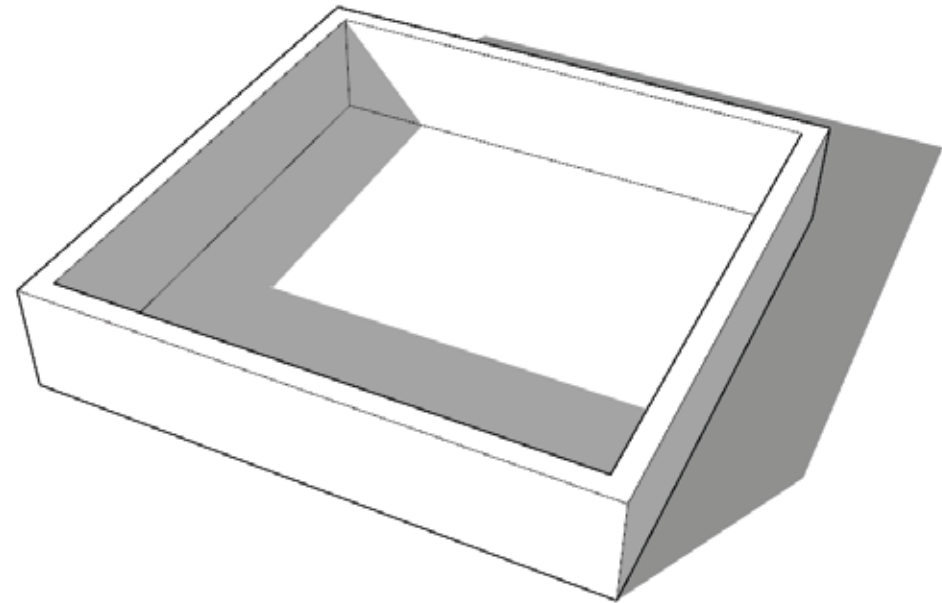
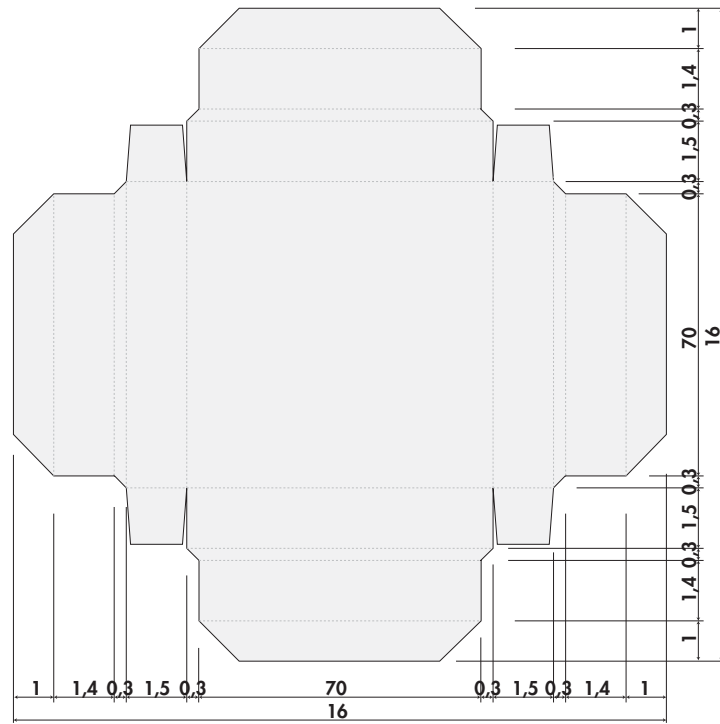

PROGETTO SCATOLA, COPERTURA SUPERIORE

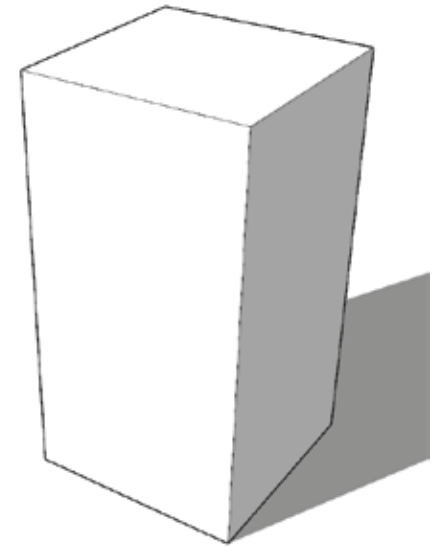
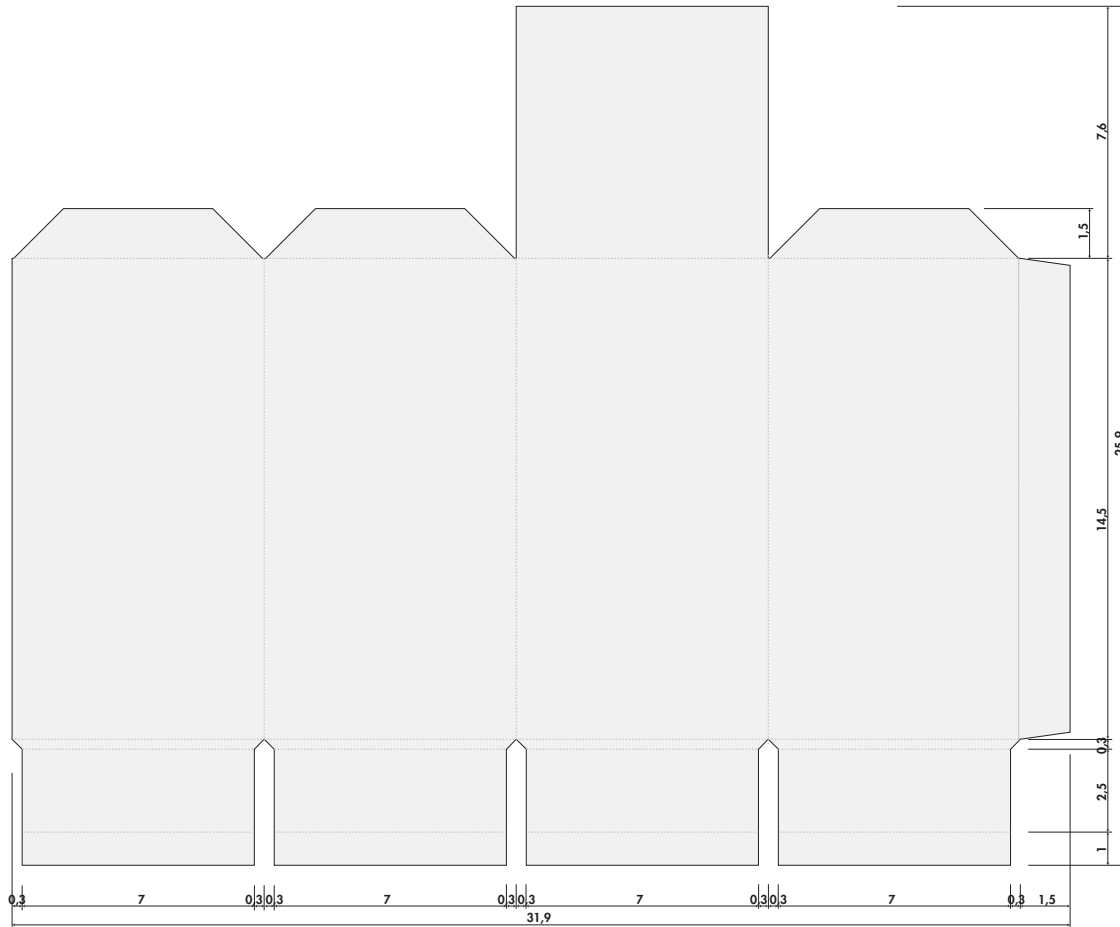

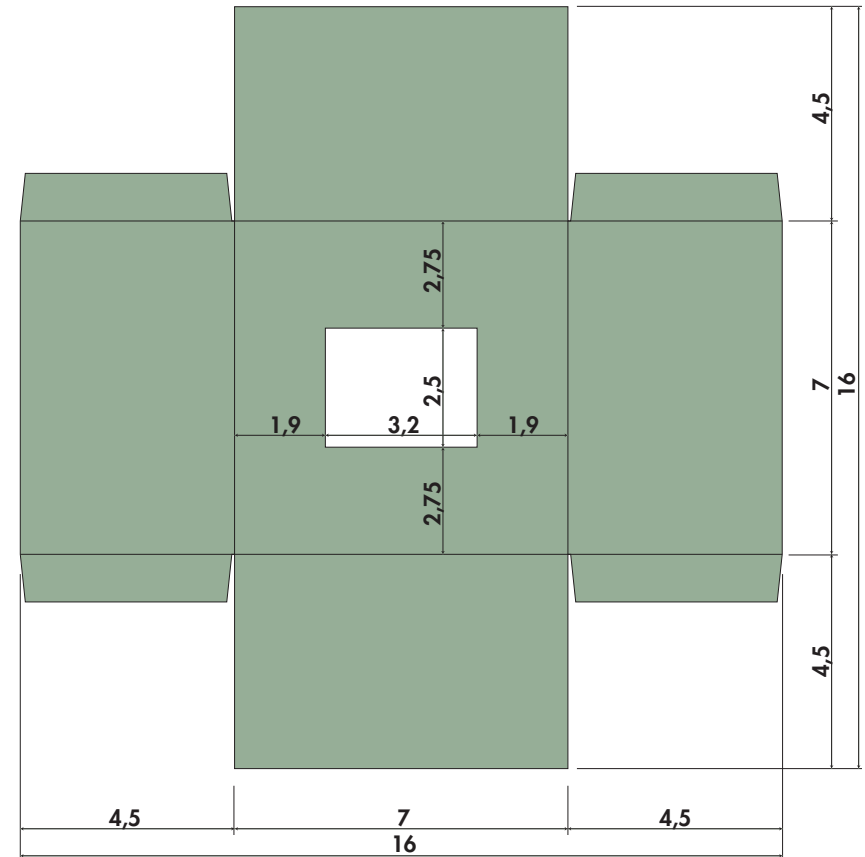
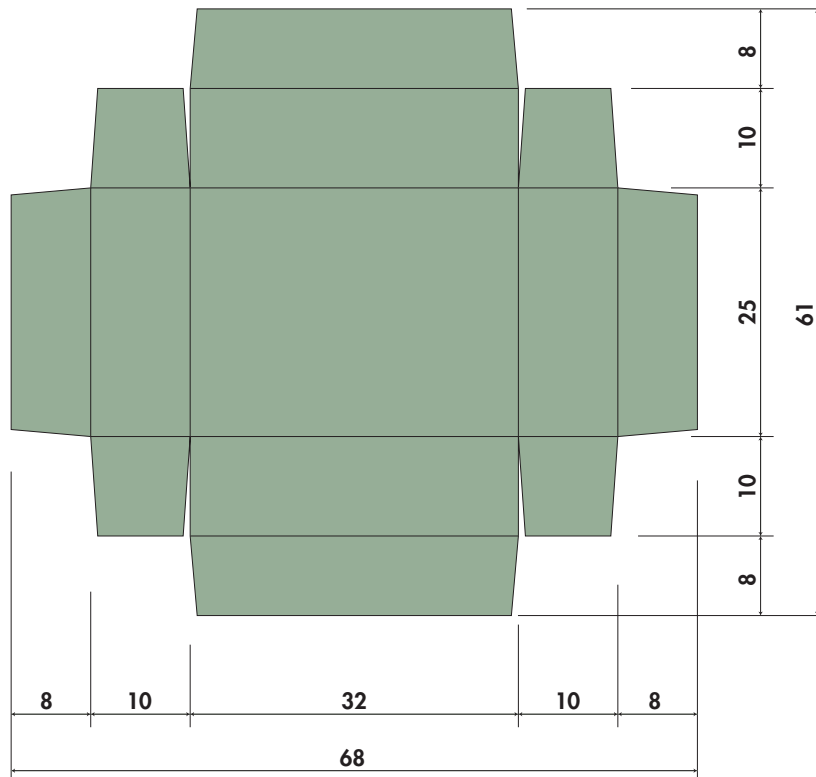











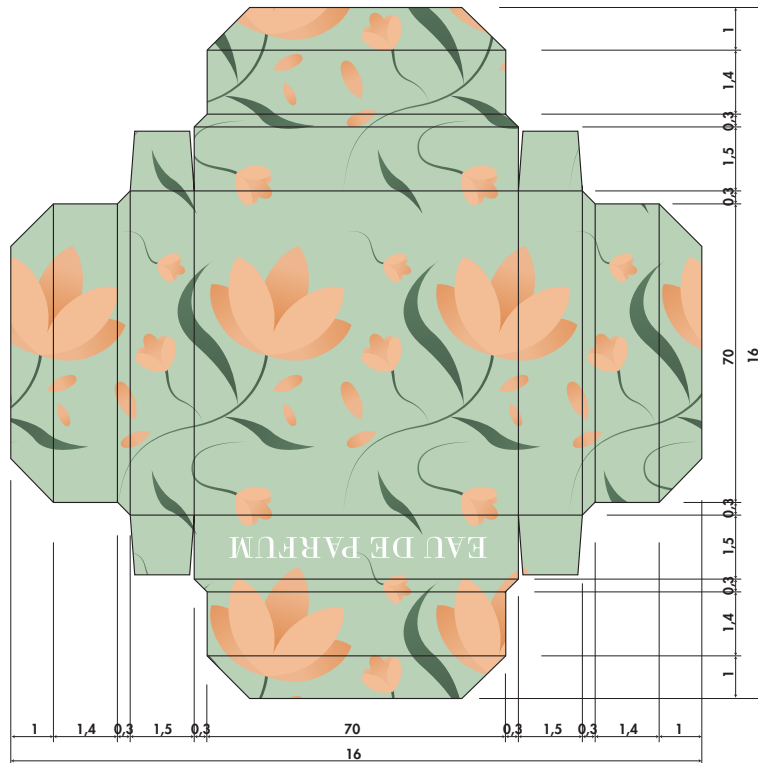







Grafico: **Loris Leone Paolo**
classe 5^aC Grafica - a.s. 2019/20